

ALL DIMENSION IN mm

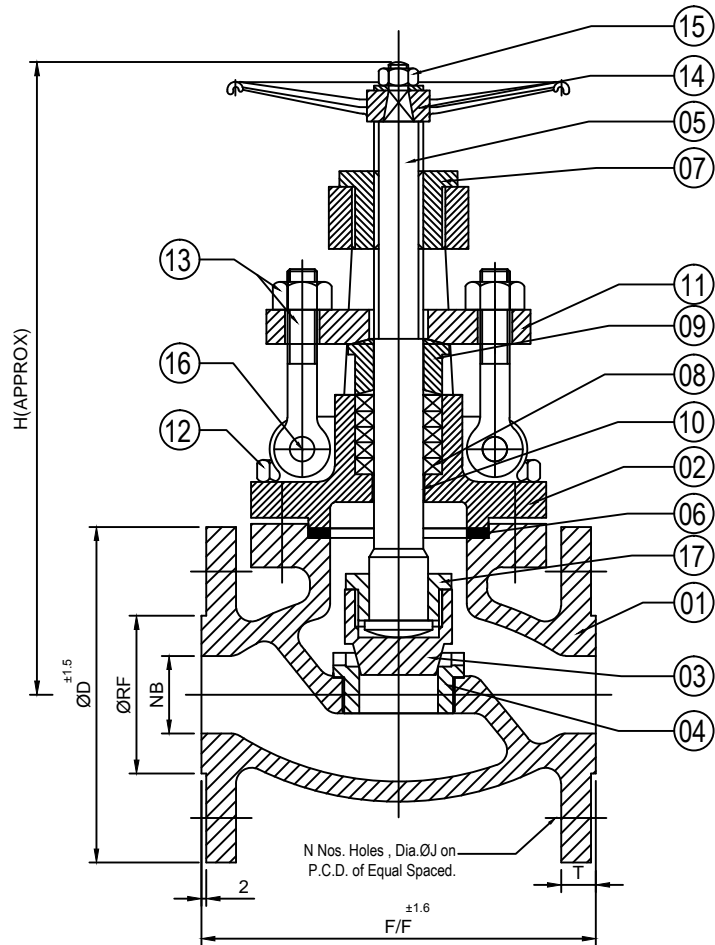

NO.	NAME OF PART	ASTM SPECIFICATION		
1	BODY	ASTM A 216 Gr. WCB	ASTM A 351 Gr. CF8	ASTM A 351 Gr. CF8M
2	BONNET	ASTM A 216 Gr. WCB	ASTM A 351 Gr. CF8	ASTM A 351 Gr. CF8M
3	DISC	S.S.410	S.S.304	S.S.316
4	SEAT RING	ASTM A 276 T 410	S.S.304	S.S.316
5	SPINDLE	ASTM A 276 T 410	S.S.304	S.S.316
6	GASKET	S.S.316 SPIRAL WOUND WITH GRAPHOIL FILLER		
7	YOKE BUSH	S.S.416	S.S.416	S.S.416
8	GLAND PACKING	TO SUIT SERVICE		
9	GLAND BUSH	ASTM A 276 T 410	S.S.304	S.S.316
10	BACK SEAT	INTEGRAL	INTEGRAL	INTEGRAL
11	GLAND FLANGE	ASTM A 216 Gr. WCB	ASTM A 351 Gr. CF8	ASTM A 351 Gr. CF8M
12	STUD & NUT	A-193 GR.B7/A-194 GR.2H	A-193 GR.B8/A-194 GR.8	A-193 GR.B8M/A-194 GR.8M
13	EYE BOLT & NUT	CARBON STEEL	CARBON STEEL	CARBON STEEL
14	HAND WHEEL	S.G. IRON	S.G. IRON	S.G. IRON
15	HAND WHEEL NUT	C.S.	C.S.	C.S.
16	EYE BOLT PIN	C.S.	C.S.	C.S.
17	DISC NUT	ASTM A 276 T 410	S.S.304	S.S.316

ALL DIMENSION ARE IN mm

SIZE ØNB		F/F	H APP.	ØD	PCD	ØRF	T	ØJ	N
INCH	MM								
1/2"	12	108.0	175.0	90	60.5	35	10	16	4
3/4"	18	117.3	180.0	100	69.9	43	10.4	16	4
1"	25	127.0	200.0	110	79.2	51	11.6	16	4
1-1/2"	38	165.1	260.0	127	98.6	73	14.6	16	4

TEST PRESSURE

HYDRAULIC TEST-ANSI 150#
BODY : 32 Kg/Cm ²
SEAT : 21 Kg/Cm ²
BACK SEAT : 21 Kg/Cm ²

AIR TEST

SEAT : 7Kg/Cm ²

STANDARD

MFG. & DESIGN	: BS 1873
INSP. & TESTING	: BS 6755
FLANGE DETAIL	: ANSI B 16.5 RF 150#
FACE TO FACE	: ANSI B 16.10



MULTITECH ENGINEERING

L-82, G.I.D.C. Estate, Nr. Water tank Odhav AHMEDABAD - 382415

DRN. : VASUDEV

GLOBE VALVE 150#
FLANGED ENDS, 15MM to 40MM

CHD. :

PRESSURE RATING - ANSI 150 #

APD. :

SCALE : NTS

DATE :

DRG.NO.: -GBV / 150 / 15 to 40 / G.D.