

ALL DIMENSION IN mm

GATE VALVE 600#

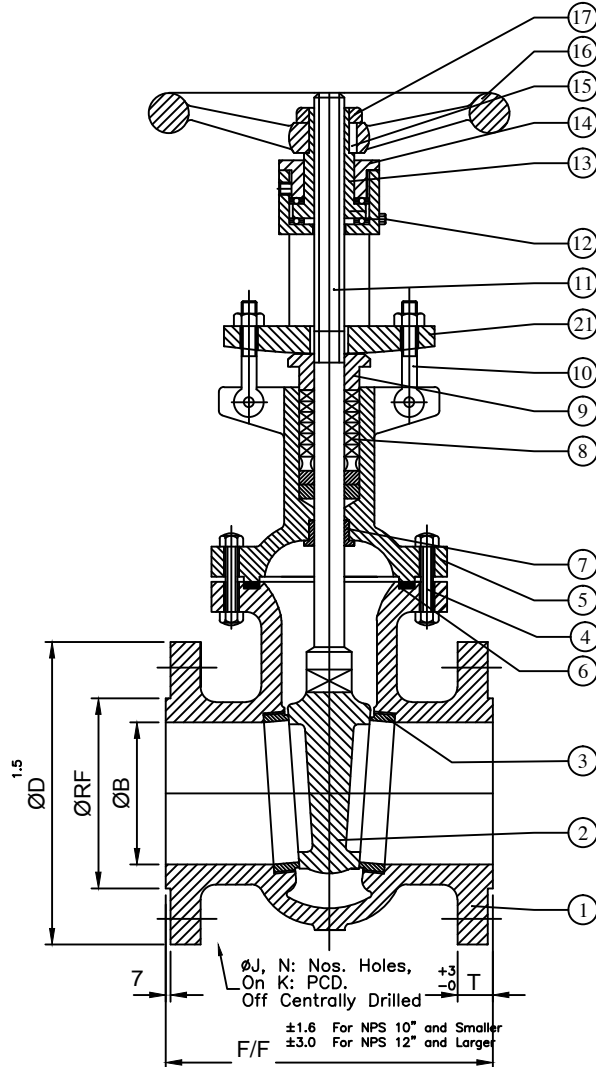

TEST PRESSURE

HYDRAULIC TEST-ANSI 600#

BODY : 158 Kg/Cm²

SEAT : 114 Kg/Cm²

BACK SEAT : 114 Kg/Cm²

AIR TEST

SEAT : 7Kg/Cm²

P.NO.	PART NAME.	MATERIAL		
		CAST STEEL	SS- 304	SS-316
1	BODY	ASTM A 216 Gr. WCB	ASTM A 351 Gr. CF8	ASTM A 351 Gr. CF8M
2	SOLID WEDGE	13% Cr. SS.	A-351 CF-8	CF - 8M
3	SEAT	13% Cr. SS.	A-351 CF-8	CF - 8M
4	STUDS/ NUTS	A193.B-7/194-2H	A-193 GR.B8/A-194 GR.8	A-193 GR.B8M/A-194 GR.8M
5	BONNET	ASTM A 216 Gr. WCB	ASTM A 351 Gr. CF8	ASTM A 351 Gr. CF8M
6	BONNET GASKET	SPIRAL WOUND SS316 WITH GRAPHITE FILLER		
7	BACK SEAT	13% Cr.SS.	INTEGRAL WITH BODY.	
8	GLAND PACKING	TO SUIT SERVICE		
9	GLAND	ASTM A 216 Gr. WCB	ASTM A 351 Gr. CF8	ASTM A 351 Gr. CF8M
10	GLAND BOLTING	A193.B-7/194-2H	A-193 GR.B8/A-194 GR.8	A-193 GR.B8M/A-194 GR.8M
11	STEM	AISI - 410.	AISI-304	AISI-316.
12	GREASE NIPPLE	COMMERCIAL QUALITY		
13	STEM NUT.	D2	D2	D2
14	STEM NUT RETAINER	C.S.	AISI 304	AISI 316
15	KEY	C.S.	C.S.	C.S.
16	HAND WHEEL	M.C.I.	M.C.I.	M.C.I.
17	HANDWHEEL NUT	M.S.	M.S.	M.S.

ALL DIMENSION ARE IN mm

SIZE		F/F	ØD	PCD	ØRF	T	ØJ	N
INCH	ØB							
2"	51	292.1	165	127	91.95	25.4	19	8
2-1/2"	64	330.2	190	149.35	104.65	28.45	22	8
3"	76	355.6	210	168.14	127	31.75	22	8
4"	102	431.8	275	215.9	157.2	38.1	25.4	8
5"	127	508	330	266.7	185.7	44.45	28	8
6"	152	558.8	355	292.1	215.9	47.75	28	12
8"	200	660.4	420	349.25	269.8	55.63	32	12
10"	248	787.4	510	431.8	323.8	63.5	35	16
12"	298	838.2	560	488.95	381	66.55	35	20

ALL DIMENSIONS ARE IN MM.



MULTITECH ENGINEERING

L-82, G.I.D.C. Estate, Nr. Water tank Odhav AHMEDABAD - 382415

DRN. : VASUDEV	GATE VALVE 600#
CHD. :	FLANGED ENDS, 50MM TO 300MM
APD. :	PRESSURE RATING - ANSI 600 #
SCALE : NTS	
DATE :	DRG.NO.: -GTV / 600 / 50-300 / G.D.

STANDARD

MFG. & DESIGN	: API 600
INSP. & TESTING	: API 598/BS. 6755
FLANGE DETAIL	: ANSI B 16.5 RF 600#
FACE TO FACE	: ANSI B 16.10